

BALT[®]

Z-251 Ergonomic Workstation

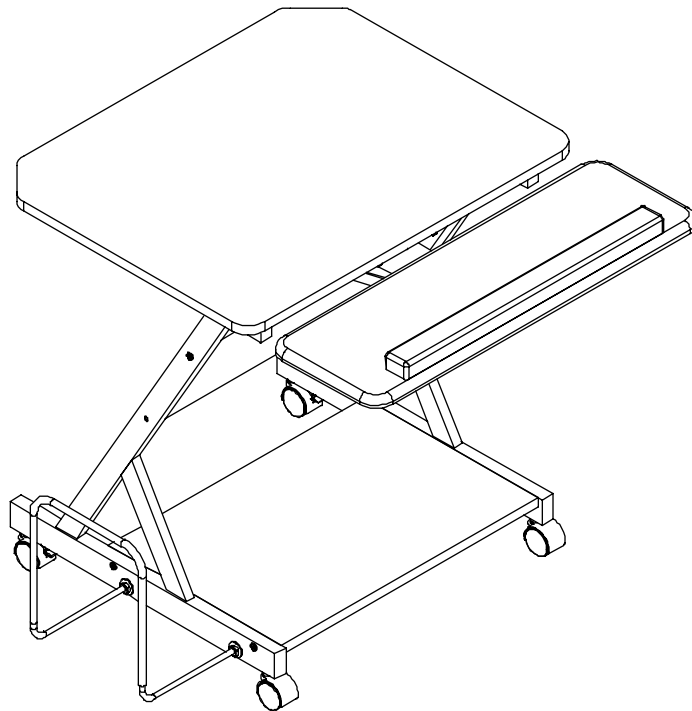











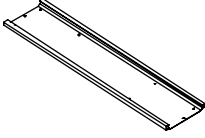
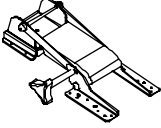
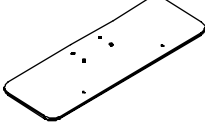
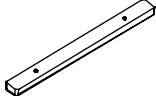
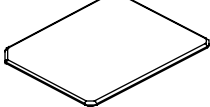
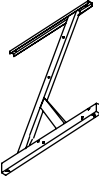
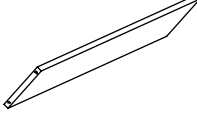
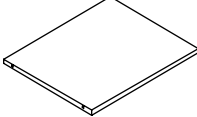
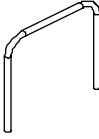
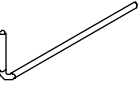



Assembly Instructions

See back for important information, including our
Toll-Free Customer Service Telephone Number

Z-251

Ergonomic Workstation

Assembly Instructions

Part	Drawing	Description	Qty	Part	Drawing	Description	Qty
P-1		Keyboard Track	1 EA	Hardware List			
P-2		Adjustment Mechanism	1 EA				
P-3		Keyboard Platform	1 EA				
P-4		Wrist Rest Pad	1 EA				
P-5		Top Platform	1 EA				
P-6		Z-Leg Assembly	2 EA				
P-7		Stability Panel	1 EA				
P-8		Bottom Shelf	1 EA				
P-9		CPU Sleeve	1 EA				
P-10		CPU Rod	2 EA				
A		Flat Head Screw	8 EA				
A1		1 1/4" Long Flat Head Screw	2 EA				
A2		Long Wood Screw	2 EA				
A3		Short Wood Screw	7 EA				
B		1-7/8" Socket Screw	8 EA				
D		Black Plastic Spacer	2 EA				
E		Hex Nut	4 EA				
F		Allen Wrench	1 EA				
G		Flat Washer	4 EA				
H		Rubber Bumper	2 EA				
J		2" Locking Caster (for front)	2 EA				
K		2" Caster (for Back)	2 EA				
L		Caster Wrench	1 EA				

Z-251 Keyboard Assembly Diagram



READ THROUGH INSTRUCTIONS FROM BEGINNING TO END BEFORE STARTING TO ASSEMBLE UNIT.

We recommend that you assemble this unit on a table.

Tools required: Philips Head Screw Driver (Power Screw Driver Preferred)
Adjustable Crescent Wrench

To Assemble:

1. Identify and Separate all the Parts and Hardware.
2. Align the Keyboard Track (P-1) in desired location on the Top Platform (P-5) and attach it using 7 Short Wood Screws (A3) as shown in illustration # 1.
3. Attach Rubber Bumper (H) using 1 Long Wood Screw (A2) at the back end of the Keyboard Track.
4. Then slide the Adjustment Mechanism (P-2) into the track as shown in illustration.
5. Move the Adjustment Mechanism (P-2) towards the back end of the Track, and attach the second Rubber Bumper (H) at the front end as shown in illustration # 2.

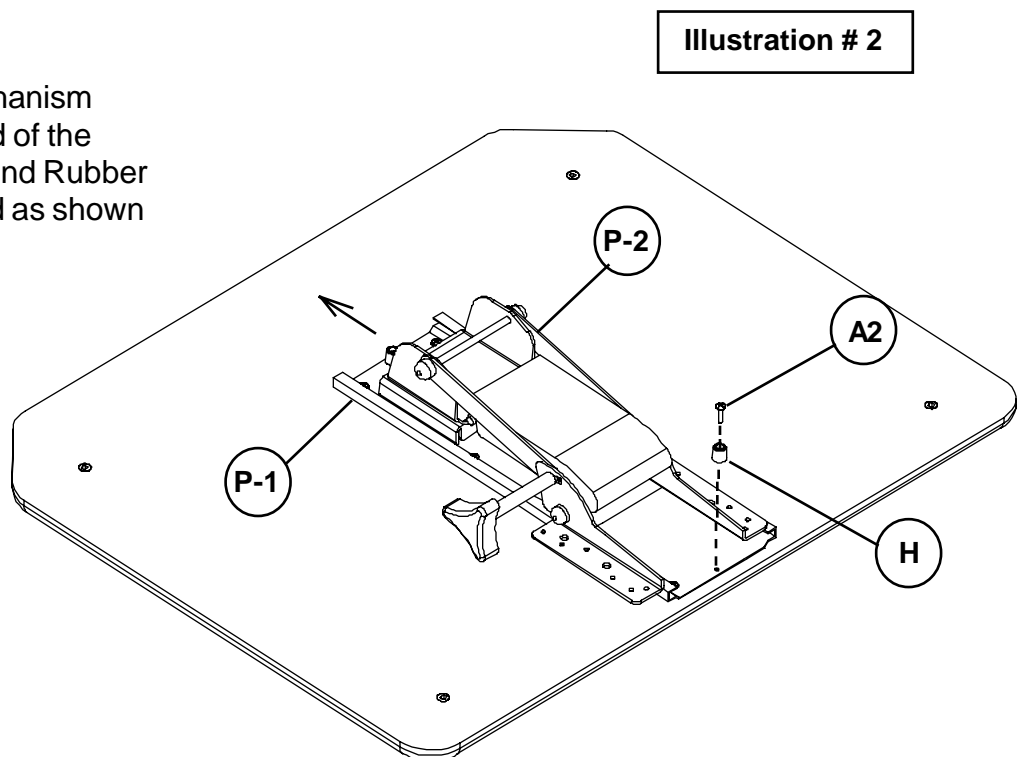
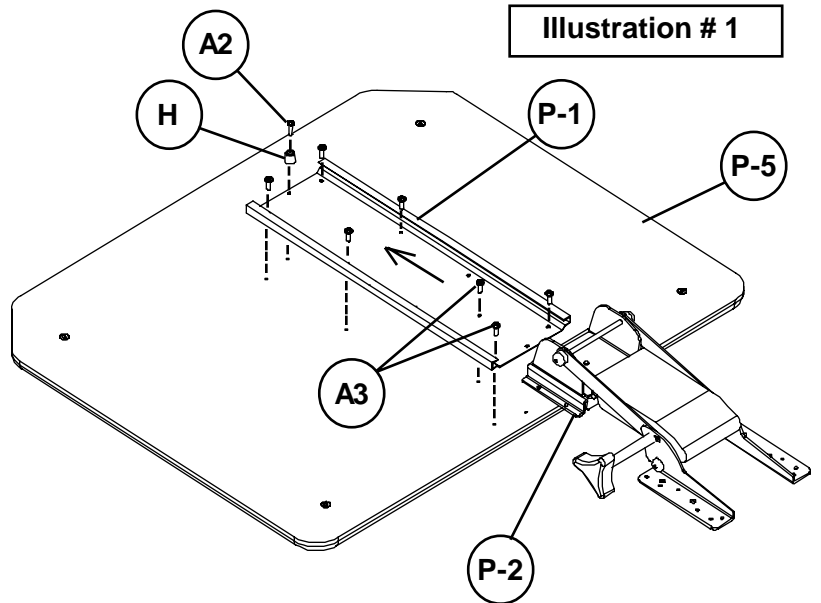

Z-251 Assembly Diagram

BALT®

6. Pull the Adjustment Mechanism (P-2) towards the front of the Track as shown in illustration # 3.

7. Align Adjustment Mechanism Brackets with the Keyboard Platform (P-3) and attach using 4 Flat Head Screws (A) as shown in illustration # 3.

8. Attach Wrist Rest Pad (P-4) to the Keyboard Platform (P-3) using (2) 1¼" Long Flat Head Screws (A1) as illustrated.

Illustration # 3

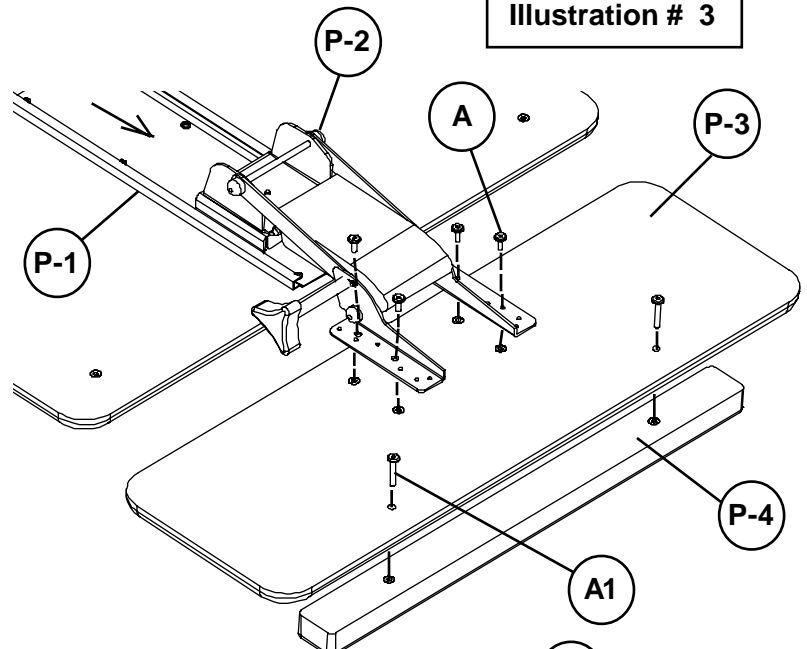

Illustration # 4

9. Place the Top Platform (P-5) with the insert nuts facing up. Attach 2 Legs (P-6) using 4 each (A) screws.
(Finger tighten only)

10. Attach Stability Panel (P-7) to the 2 Legs (P-6) using 4 (B) Screws as shown in illustration # 4.

11. Attach Bottom Shelf (P-8) to the 2 Legs (P-6) using 4 (B) Screws as shown in illustration.

(Tighten all the screws at this time)

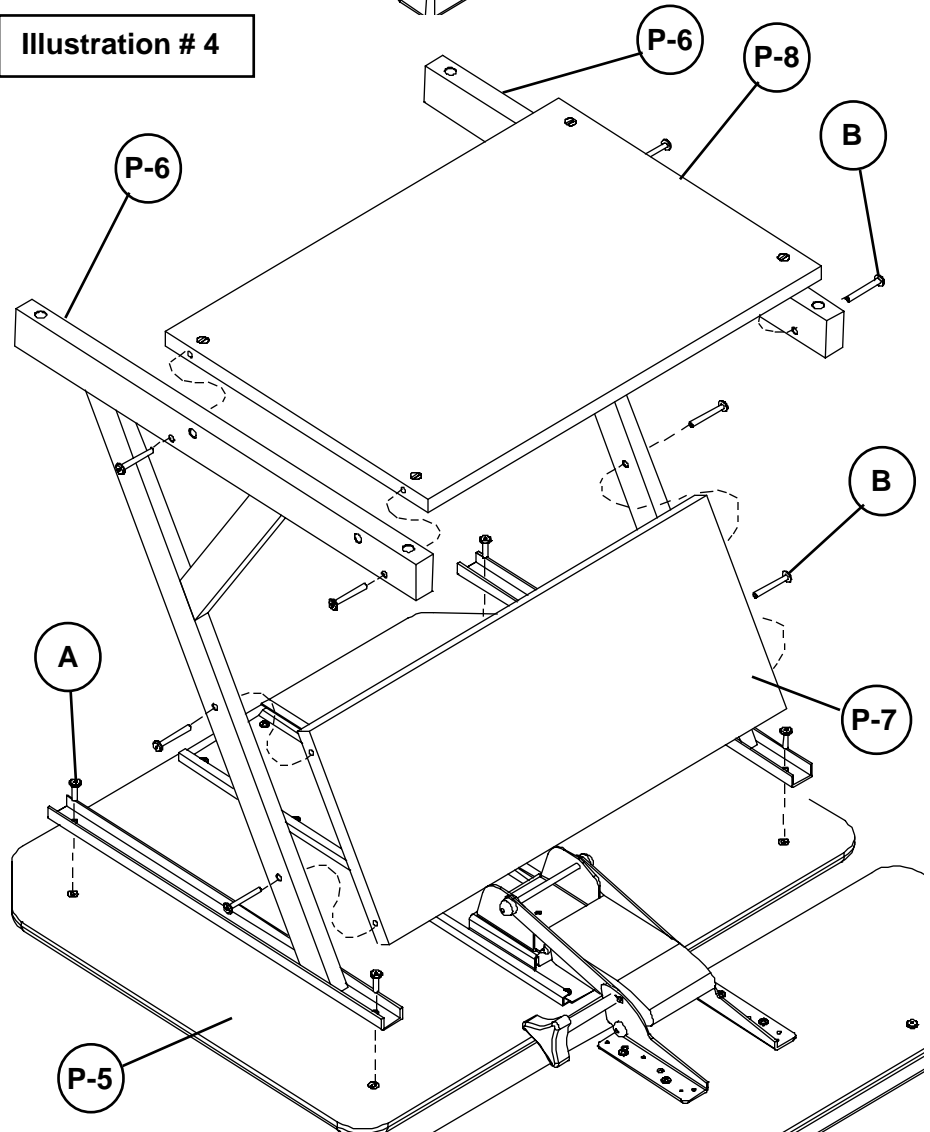

12. Attach (2) each J Locking Casters to the front of the 2 each Legs and (2) each K Casters to the back of the Legs.
13. Attach (2) each CPU Rods (P-10) to either Leg (P-6) as shown in illustration # 5 .
Secure each rod with (2) each E Hex nuts, (2) each G Flat Washers and (1) each D Black spacer. Slide CPU Sleeve (P-9) over ends of CPU Rods (P-10) as shown in illustration #5.
14. Tighten all screws securely.

Illustration # 5

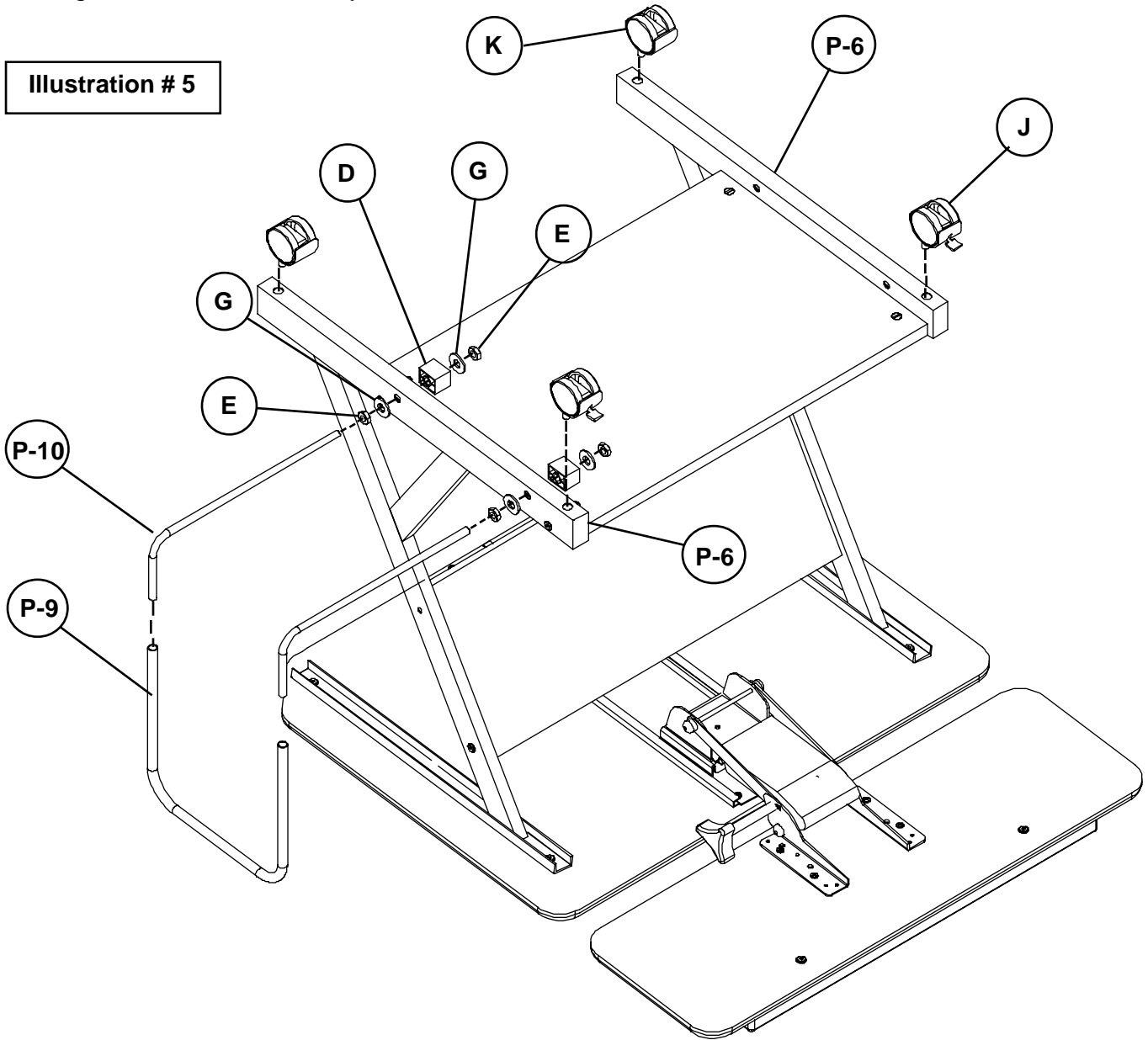

Z-251asm3-03/06/00

Do not use unless all screws are tight. At least every six months, check all screws to be sure they are tight. If parts are missing, broken, damaged, or worn, stop use of the product until repairs are made by your dealer using factory authorized parts.

**Should you require assistance during assembly, please call our Customer Service Department
Monday - Friday 8 a.m. - 5 p.m. Central Standard Time
Toll-Free Customer Service
1-800-749-2258**