

1. Attach VESA Bracket to Monitor

a) Select 75mm or 100mm VESA bracket to match hole pattern on back of monitor.

b) Place VESA bracket on monitor with raised portion facing away from monitor and attach using four screws provided. If mounting location on monitor is recessed, use spacers between monitor and VESA bracket (fig. 1).

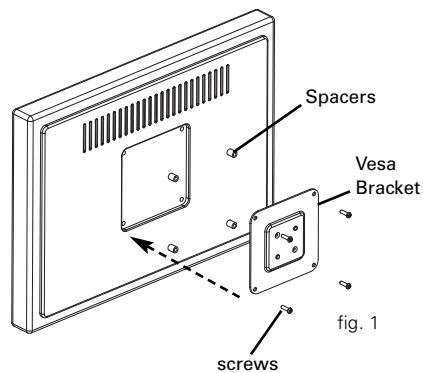

2. Attach FEA to Monitor

a) The face of the FEA has 8 holes offering 3 possible mounting positions as shown (fig. 2). The middle position is appropriate for most monitors and users. However, choose the upper position for a higher monitor range or the lower position for a lower monitor range, as desired.

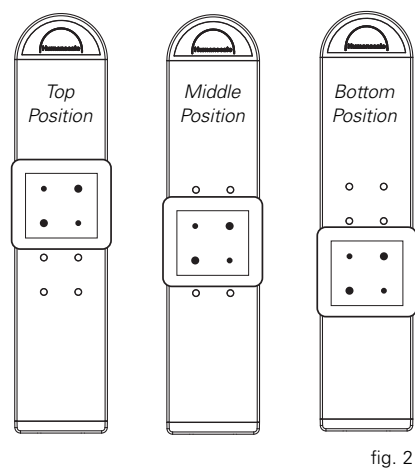

b) Once position is determined, align raised guide pins on VESA bracket with desired holes on face of FEA and press together. Make sure the guide pins are fully inserted into FEA holes. If so, the FEA should feel secure against the VESA bracket (fig. 3).

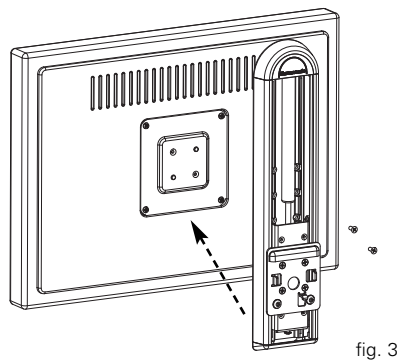

c) Attach FEA to monitor using two screws provided. (fig. 3)

Note: If mounting monitor to bottom position on FEA, first attach top screw and then compress cylinder and attach bottom screw (fig. 4).

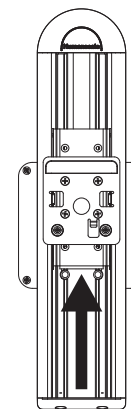

3. Adjust Rear Bracket on FEA (Optional)

For additional height range adjustment, the mounting plate on the back of the FEA can be adjusted up or down by removing the four screws, repositioning as desired, and reinstalling the screws.

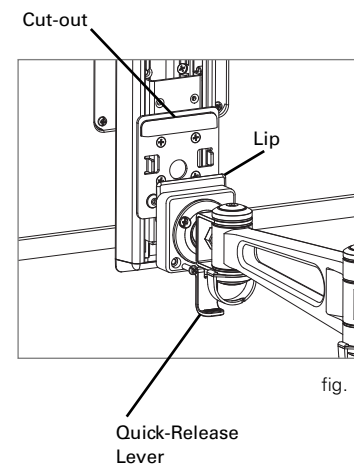

4. Attach Monitor to Monitor Arm

Place cut-out on mounting plate over Lip at end of Arm. If your arm is equipped with a Quick-Release Lever, simply push bottom of monitor into Arm until you hear a click. To remove, depress Quick Release Lever and remove monitor from Arm (fig. 5).

If your Arm does not have a Quick Release Lever, secure monitor to Arm using two screws, as shown (fig. 6).

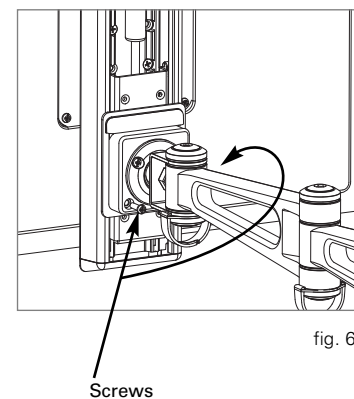

M7 Front End Adjuster Installation Instructions



www.humanscale.com

